

## Features:

- Support 10GBASE-LR/LW and CPRI wireless application
- Up to 1.4km transmission on SMF
- 1310nm FP laser and PIN receiver
- SFI high speed electrical interface
- 2-wire interface with integrated Digital Diagnostic monitoring
- SFP+ MSA package with duplex LC connector
- Single +3.3V power supply
- Power consumption less than 1 W
- Operating case temperature:  
Commercial Temp: 0~70°C  
Industry Temp: -40~+85°C



## Regulatory Compliance

Table 1 – Regulatory Compliance

Feature	Standard	Performance
Electrostatic Discharge (ESD) to the Electrical Pins	MIL-STD-883E Method 3015.7	Class 1(>1000V for SFI pins, >2000V for other pins.)
Electrostatic Discharge (ESD) to the Duplex LC Receptacle	IEC 61000-4-2 GR-1089-CORE	Compatible with standards
Electromagnetic Interference (EMI)	FCC Part 15 Class B EN55022 Class B (CISPR 22B) VCCI Class B	Compatible with standards
Immunity	IEC 61000-4-3	Compatible with standards
Laser Eye Safety	FDA 21CFR 1040.10 and 1040.11 EN60950, EN (IEC) 60825-1,2	Compatible with Class I laser product.
RoHS	EU 2015/863	Compliant with standards

## Absolute Maximum Ratings

Table 2 – Absolute Maximum Ratings

Parameter	Symbol	Min.	Typical	Max.	Unit	Notes
Storage Temperature	TS	-40	-	+85	°C	
Supply Voltage	VCC	-0.5	-	+4.0	V	
Operating Relative Humidity	RH	-	-	+85	%	

## Recommended Operating Conditions

**Table 3 – Recommended Operating Conditions**

Parameter	Symbol	Min.	Typical	Max.	Unit	Notes
Operating Case Temperature	T <sub>OPR</sub>	0	-	70	°C	1
		-40	-	85		2
Power Supply Voltage	V <sub>CC</sub>	3.14	3.3	3.47	V	
Supply current				300	mA	
Power Dissipation	P <sub>D</sub>	-	-	1.0	W	
Bit Rate	BR	2.4576	9.8304	10.3125	Gb/s	
Transmission Distance	TD	2	-	1,400	m	With SMF

Notes:

1. Commercial temp
2. Industry Temp

## Optical and Electrical Characteristics

**Table 4 – Transmitter Optical Specifications**

Parameter	Symbol	Min.	Typical	Max.	Unit	Notes
Center Wavelength Range	$\lambda_c$	1260	1310	1355	nm	
Average Output Power	P <sub>OUT</sub>	-8.2	-	0.5	dBm	1
Average Output Power (Laser Off)	P <sub>OUT-OFF</sub>	-	-	-30	dBm	1
Extinction Ratio	ER	3.5	-	-	dB	2
Transmitter and Dispersion Penalty	TDP	-	-	3.2	dB	
Optical Return Loss Tolerance	ORLT	-	-	12	dB	
Optical Eye Mask	Compliant with IEEE 802.3-2018					2

Note:

1. The optical power is launched into SMF.
2. Measured with a PRBS 2<sup>31</sup>-1 test pattern @10.3125Gbps..

**Table 5 – Receiver Optical Specifications**

Parameter	Symbol	Min.	Typical	Max.	Unit	Notes
Center Wavelength Range	$\lambda_c$	1260	-	1355	nm	
Receiver Sensitivity	P <sub>IN-SENS</sub>	-	-	-14.4	dBm	1
Receiver Sensitivity in OMA	P <sub>IN-SENS(OMA)</sub>	-	-	-12.6	dBm	1
Receiver Overload	P <sub>IN-OL</sub>	0.5	-	-	dBm	1
Receiver Reflectance	Ref	-	-	-12	dB	
LOS Assert	LOS <sub>A</sub>	-30	-	-	dBm	
LOS Deassert	LOS <sub>D</sub>	-	-	-16	dBm	
LOS Hysteresis	LOS <sub>H</sub>	0.5	-	-	dB	

Note:

1. Measured with a PRBS 2<sup>31</sup>-1 test pattern @10.3125Gbps, BER≤10<sup>-12</sup>.

**Table 6 – Electrical Specifications**

Transmitter (Module Input)						
Parameter	Symbol	Min.	Typical	Max.	Unit	Notes
Differential Data Input Amplitude	V <sub>IN,P-P</sub>	180	-	700	mVpp	
Input Differential Impedance	Z <sub>IN</sub>	85	100	115	Ω	
Tx_Fault	Normal Operation	V <sub>OL</sub>	0	-	0.8	V
	Transmitter Fault	V <sub>OH</sub>	2.0	-	V <sub>CC</sub> +0.3	V
Tx_Disable	Normal Operation	V <sub>IL</sub>	0	-	0.8	V
	Laser Disable	V <sub>IH</sub>	2.0	-	V <sub>CC</sub>	V
Receiver (Module Output)						
Differential Data Output Amplitude	V <sub>OUT,P-P</sub>	300	-	850	mVpp	
Output Differential Impedance	Z <sub>O</sub>	80	100	120	Ω	
Rx_LOS	Normal Operation	V <sub>OL</sub>	0	-	0.8	V
	Lose Signal	V <sub>OH</sub>	2.0	-	V <sub>CC</sub> +0.3	V

**Recommended Host Board Power Supply Circuit**

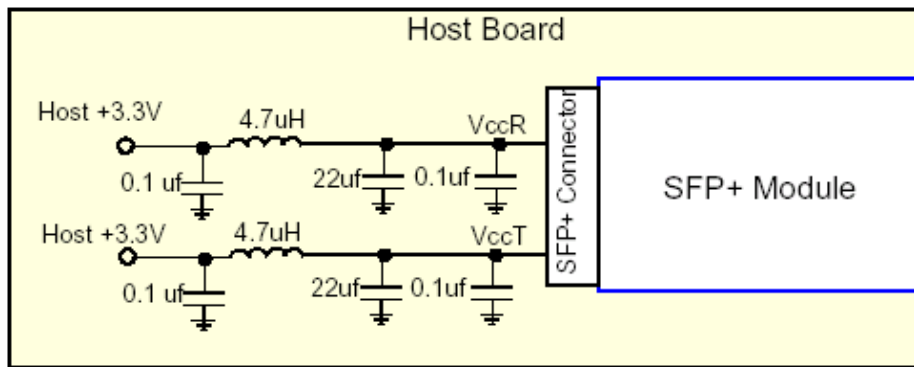

Figure 1, Recommended Host Board Power Supply Circuit

**Recommended Interface Circuit**

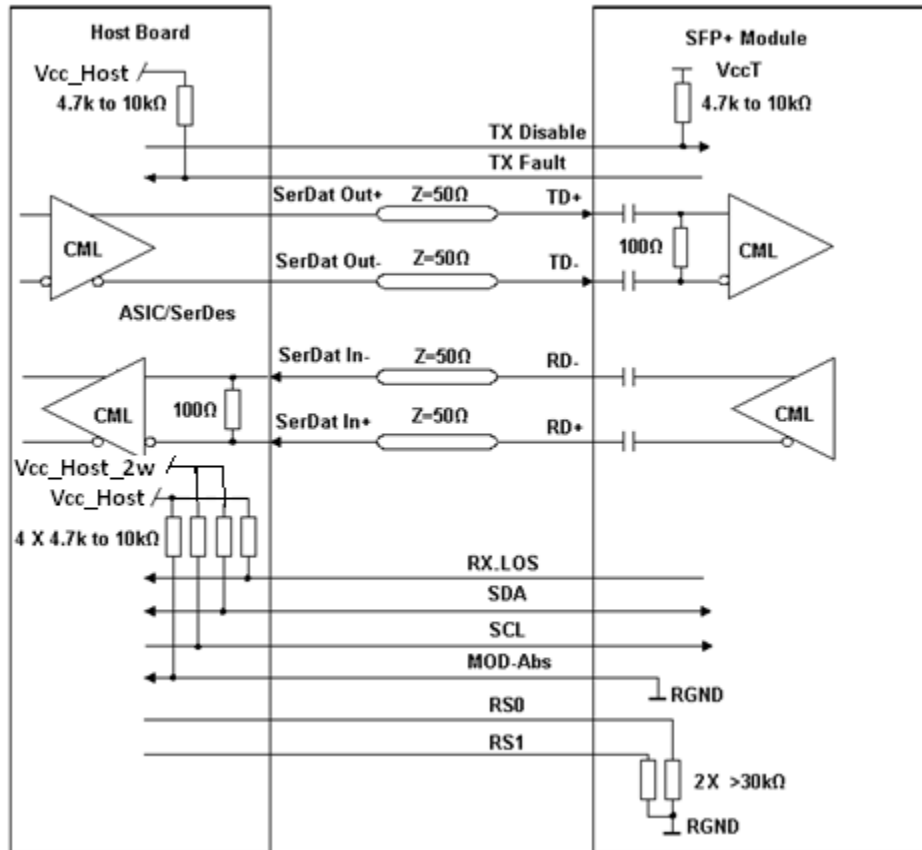
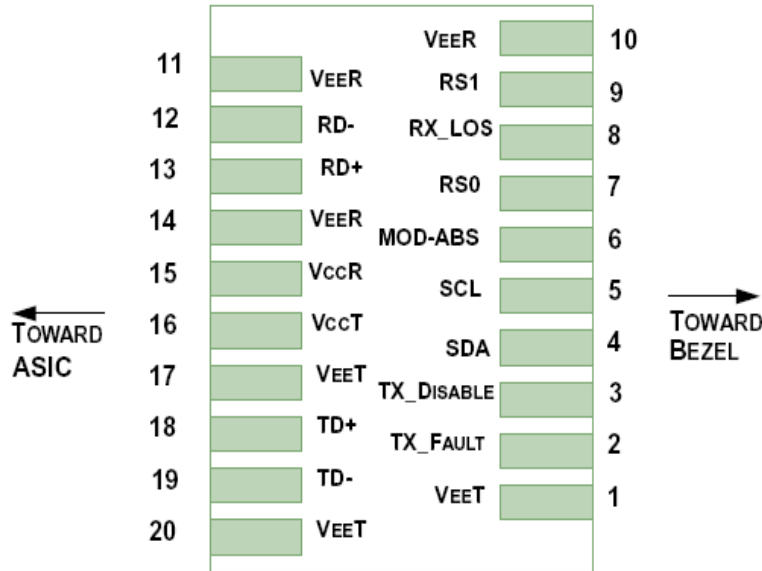

Figure 2, Recommended Interface Circuit

**Pin Definitions**



**Figure 3, Pin View**

**Table 7 – Pin Definitions**

Pin	Logic	Symbol	Description	Notes
1		VEET	Module Transmitter Ground	1
2	LVTTL-O	TX_FAULT	Module Transmitter Fault	2
3	LVTTL-I	TX_DISABLE	Transmitter Disable; Turns off transmitter laser output	3
4	LVTTL-I/O	SDL	2-Wire Serial Interface Data Line (MOD-DEF2)	
5	LVTTL-I/O	SCL	2-Wire Serial Interface Clock (MOD-DEF1)	
6		MOD_ABS	Module Absent, connected to VEET or VEER in the module	2
7	LVTTL-I	RS0	Rate Select 0, NOT implement	4
8	LVTTL-O	RX_LOS	Receiver Loss of Signal Indication (in FC designated as RX_LOS, in SONET designated as LOS, and in Ethernet designated as NOT Signal Detect)	2
9	LVTTL-I	RS1	Rate Select 1, NOT implement	4
10		VEER	Module Receiver Ground	1
11		VEER	Module Receiver Ground	1
12	CML-O	RD-	Receiver Inverted Data Output	
13	CML-O	RD+	Receiver Non-Inverted Data Output	
14		VEER	Module Receiver Ground	1
15		VccR	Module Receiver 3.3 V Supply	
16		VccT	Module Transmitter 3.3 V Supply	
17		VEET	Module Transmitter Ground	1
18	CML-I	TD+	Transmitter Non-Inverted Data Input	
19	CML-I	TD-	Transmitter Inverted Data Input	
20		VEET	Module Transmitter Ground	1

**Notes:**

1. The module ground pins are isolated from the module case.
2. The pins shall be pulled up with 4.7K-10Kohms to a voltage between 3.14V and 3.46V on host board.
3. The pin is pulled up to  $V_{CCT}$  with a 4.7K-10K $\Omega$  resistor in the module.
4. The pins are pulled low to  $V_{EET}$  with a >30k $\Omega$  resistor in the module.

**Mechanical Diagram**

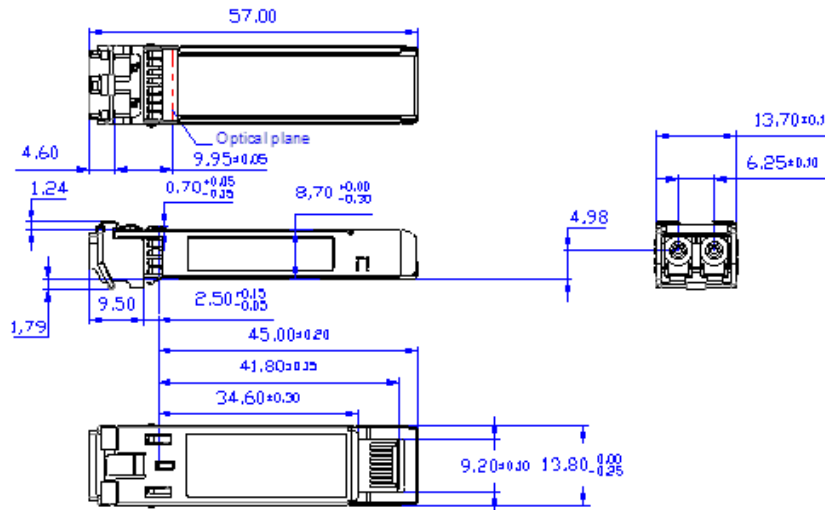

**Figure 4, Outline Drawing**

**Order Information**

**Table 8 – Order Information**

Part No.	Application	Data Rate	Laser Source	Fiber Type
SPP-10E-LR-IDFS	CPRI, 10GBASE-LR/LW -40~85°C	10.3125G	1310nm FP	SMF
SPP-10E-LR-CDFS	CPRI, 10GBASE-LR/LW 0~70°C			

## Warnings

Handling Precautions: This device is susceptible to damage as a result of electrostatic discharge (ESD). A static free environment is highly recommended. Follow guidelines according to proper ESD procedures.

Laser Safety: Radiation emitted by laser devices can be dangerous to human eyes. Avoid eye exposure to direct or indirect radiation.

## Legal Notice

### IMPORTANT NOTICE!

All information contained in this document is subject to change without notice, at Source Photonics' sole and absolute discretion. Source Photonics warrants performance of its products to current specifications only in accordance with the company's standard one-year warranty; however, specifications designated as "preliminary" are given to describe components only, and Source Photonics expressly disclaims any and all warranties for said products, including express, implied, and statutory warranties, warranties of merchantability, fitness for a particular purpose, and non-infringement of proprietary rights. Please refer to the company's Terms and Conditions of Sale for further warranty information.

Source Photonics assumes no liability for applications assistance, customer product design, software performance, or infringement of patents, services, or intellectual property described herein. No license, either express or implied, is granted under any patent right, copyright, or intellectual property right, and Source Photonics makes no representations or warranties that the product(s) described herein are free from patent, copyright, or intellectual property rights. Products described in this document are NOT intended for use in implantation or other life support applications where malfunction may result in injury or death to persons. Source Photonics customers using or selling products for use in such applications do so at their own risk and agree to fully defend and indemnify Source Photonics for any damages resulting from such use or sale.

© Copyright Source Photonics, Inc. 2007-2021

All Rights Reserved.

All information contained in this document is subject to change without notice. The products described in this document are NOT intended for use in implantation or other life support applications where malfunction may result in injury or death to persons.

The information contained in this document does not affect or change Source Photonics product specifications or warranties. Nothing in this document shall operate as an express or implied license or indemnity under the intellectual property rights of Source Photonics or third parties. All information contained in this document was obtained in specific environments, and is presented as an illustration. The results obtained in other operating environments may vary.

THE INFORMATION CONTAINED IN THIS DOCUMENT IS PROVIDED ON AN "AS IS" BASIS. In no event will Source Photonics be liable for damages arising directly from any use of the information contained in this document.

## Contacts

### US Headquarters

8521 Fallbrook Ave, Suite 200  
West Hills, CA 91306, USA  
Tel: +1(818) 773-9044  
Fax: +1(818) 576-9486

### China

Building #2&5, West Export Processing  
Zone No. 8 Kexin Road, Hi-Tech Zone  
Chengdu, 611731, China  
Tel: +86-28-8795-8788  
Fax: +86-28-8795-8789

### Taiwan

9F, No 81, Shui Lee Rd.  
Hsinchu, Taiwan R.O.C.  
Tel: +886-3-5169222  
Fax: +886-3-5169213

[www.sourcephotonics.com](http://www.sourcephotonics.com)