



OC-192/STM-64 80km SFF Transponder

(TP-TS-08-XXXXX)

Features

- ◆ Compliant with the 300 pin MSA in a compact size
- ◆ Support transmission distance of 80km
- ◆ Support multi-rate operation from 9.953Gb/s to 10.709Gbps
- ◆ 1550nm externally EA modulated laser
- ◆ Wide dynamic range InGaAs APD receiver
- ◆ 1:16 MUX/DEMUX integrated
- ◆ 16-bit parallel 622.08Mbps LVDS data interface
- ◆ Selectable dual fixed-rate jitter clean-up which can be bypassed for multi-rate operation
- ◆ Compliant I2C MSA (Edition 4.0) interface for monitoring/control
- ◆ Supply voltage: +5.0V, +3.3V, +1.8V
- ◆ Operating case temperature: -5°C to +70°C

Applications

- ◆ Metro network SDH / SONET system
- ◆ 10 Gigabit Ethernet system
- ◆ Forward Error Correction (FEC) system
- ◆ Optical Transport Network (OTN) System

Standard

Compliant with 300-PIN MSA
 Compliant with ITU-T G.691
 Compliant with ITU-T G.959.1
 Compliant with Telcordia GR-253
 Compliant with OIF SFI-4 interface
 Compliant with Telcordia GR-468-Core
 Compliant with IEC-60825-1 Class I

Description

TP-TS-08-XXXXX is intended for 1550nm system applications with reaches of up to 80km, which is designed to provide high optical performance for SONET OC-192 / SDH STM-64.

The transmitter converts the electrical data into 10Gbit/s optical signal, which uses 1550nm externally EA modulated laser with specified driving circuit.

At the receiving side, the incoming data stream is received at 10Gb/s APD receiver, which converts it into a 10Gb/s electrical data stream.

The MUX section multiplexes 16 parallel 622Mb/s electrical channels into a 10Gb/s series data stream and sent it to the transmitter. And the DEMUX section demultiplexes the 10Gb/s electrical data stream into 16 parallel 622Mb/s electrical channels. The parallel data is sent out to and get from the 300-pin MSA (Multi Source Agreement) compliant connector.

The transmitter and receiver reference clock rates are selectable for divide by 16 or 64.

Block Diagram

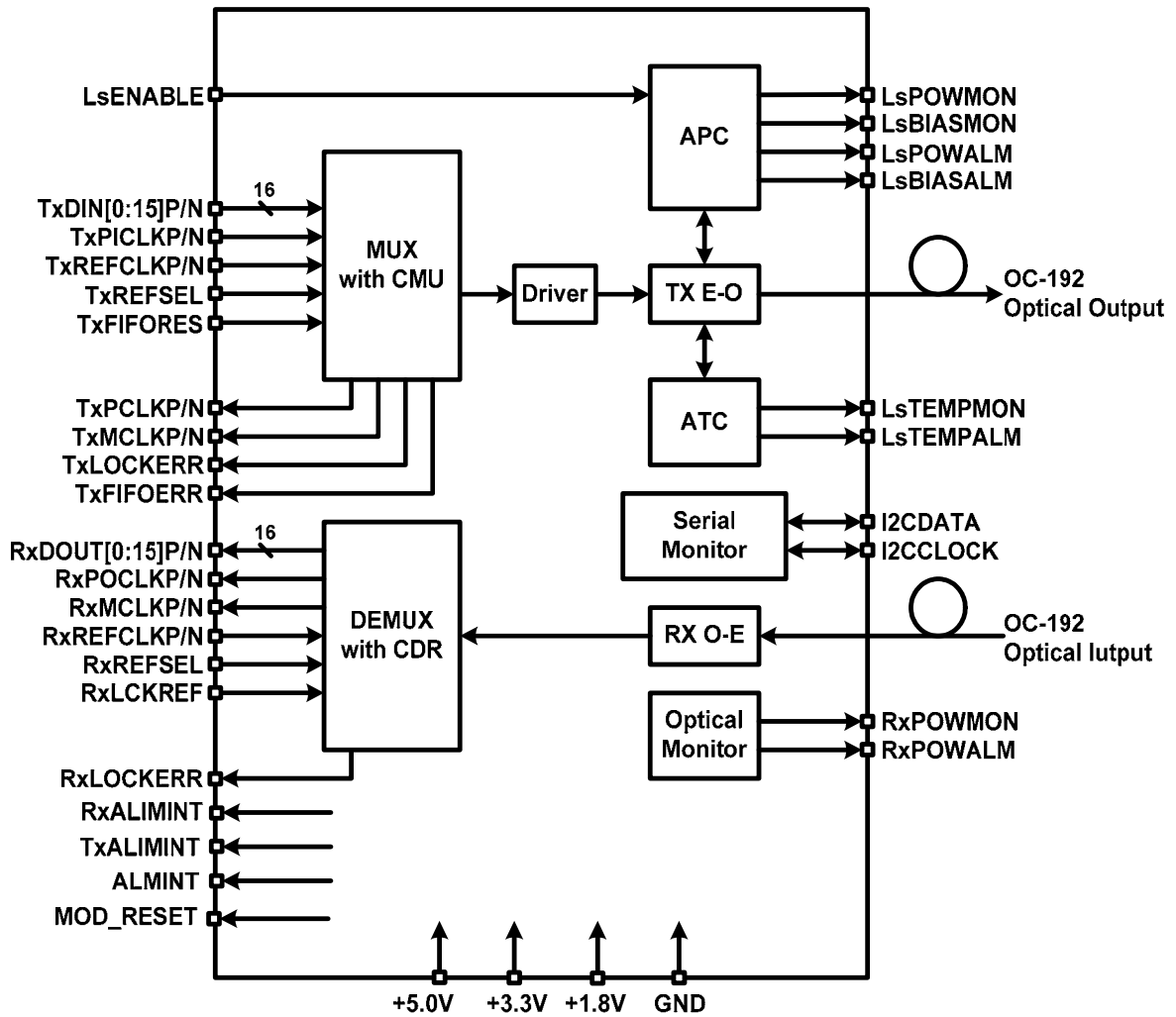

Figure 1, Block Diagram of Transponder

Absolute Maximum Ratings

Stresses in excess of the Absolute Maximum Ratings can cause permanent damage to the device.

Table 1- Absolute Maximum Ratings

Parameter	Symbol	Min.	Max.	Unit
Storage Temperature	T_S	-40	85	°C
Operating Case Temperature	T_{cm}	-10	75	°C
Supply Voltage	V_{cc}	-0.5	6.0	V
	V_{dd1}	-0.5	4.2	V
	V_{dd2}	-0.5	3.3	V
Operating Relative Humidity (non-condensing)	RH		85	%
Electro-Static Discharge	ESD		2000	V
Input Optical Power	P_{in}		+1	dBm

Recommended Operating Conditions

Specified performance should be maintained over all conditions in the table below, and damage to the device may occur over the specs for an extended period of time.

Table 2 - Recommended Operating Conditions

Parameter	Symbol	Min.	Typ.	Max.	Unit
Operating Case Temperature	T_C	-5		70	°C
Supply Voltage	V_{cc}	4.75	5.0	5.25	V
	V_{dd1}	3.13	3.3	3.46	V
	V_{dd2}	1.71	1.8	1.89	V
Supply Current	I_{cc}		70	150	mA
	I_{dd1}		600	1500	mA
	I_{dd2}		620	1000	mA
Power consumption	P_d		4	7	W
Power supply noise rejection				50	mVp-p

Optical Interface Characteristics

Table 3 - Optical Characteristics

Parameter	Symbol	Min.	Typical	Max.	Unit	Notes
Transmitter						
Centre Wavelength	λ_C	1530		1565	nm	
Output Power	$P_{OUT-BOL}$	3		6	dBm	1
Output Power at laser disable	$P_{OUT-OFF}$			-30	dBm	
Spectral Width (-20dB)	$\Delta\lambda_{20dB}$			0.4	nm	
Side Mode Suppression Ratio	SMSR	30			dB	
Extinction Ratio	ER	9			dB	
Chromatic Dispersion				1600	ps/nm	
Output Optical Eye	Compliant with Telcordia GR-253-CORE and ITU-T G.691					
Jitter Generation	20kHz~80MHz			0.3	UI	2
	4MHz~80MHz			0.1	UI	2
Receiver						
Centre Wavelength	λ_C	1290		1600	nm	
Receiver Sensitivity	P_{IN-BOL}			-24	dBm	3
Receiver Overload	P_{IN-MAX}	-9			dBm	3
Optical Path Penalty				2	dB	
Reflection of Receiver				-27	dB	
Jitter Tolerance	Compliant with Telcordia GR-253 and ITU-T G.825					
Jitter Transfer	Compliant with Telcordia GR-253 and ITU-T G.825					

Notes:

1. The optical power is launched into SMF.
2. Measured with a NRZ PRBS $2^{31}-1$ test pattern @ 9.95328Gbps.
3. Measured with a NRZ PRBS $2^{31}-1$ test pattern @ 9.95328Gbps, BER $\leq 1 \times 10^{-12}$.

Electrical Interface Characteristics

Table 4 - LVDS Input/Output Specification

Parameter	Symbol	Min.	Typical	Max.	Unit	Notes
LVDS interface						
Input Differential Voltage	V_{ID}	100		600	mV	
Input Differential impedance	R_{ID}		100		Ω	
Output Differential Voltage	V_{OD}	250		400	mV	
Output Differential impedance	R_{OD}		100		Ω	
Output Common Mode Voltage	V_{CM}	1.1		1.3	V	
Rise Time/Fall time	$T_{rise/fall}$	100		300	ps	
Clock Signal Duty Cycle	T_{DC}	45	50	55	%	

Definition of Differential Voltage Levels

Table 5 – LVPECL Input Specification (Reference Clocks)

Parameter	Symbol	Min.	Typical	Max.	Unit	Notes
Input Differential Voltage	V_{ID}	300		1000	mV	
Differential Input Impedance	R_{ID}		100		Ω	
Clock Signal Duty Cycle	T_W/T_O	45		55	%	

Table 6 - LVTTTL Input/Output Specification

Parameter	Symbol	Min.	Typical	Max.	Unit	Notes
Input High Voltage	V_{IH}	2.0		Vdd	V	
Input Low Voltage	V_{IL}	GND		0.8	V	
Output High Voltage	V_{IH}	2.4		Vdd	V	
Output Low Voltage	V_{IL}	GND		0.4	V	

Clock and Data Interfaces

There are seven clock interfaces to the transponder. This section details the specific functions, capabilities, and limitations of each. Note that all clock rates shown are at STM-64/OC-192 rate, but should be scaled appropriately for other data rates.

The LVPECL TxREFCLK, provided via the 300-pin interface, may be at 1/16 or 1/64 of the transmitted serial data rate. The TxREFCLK must be synchronous with the TxPICKL. There are several approaches to ensure this synchronous relationship. The two most common are

- 1) locking the TxPICKL to the TxPCLK out of the transponder
- 2) generating TxPICKL and TxREFCLK from the same clock on the line-card.

The LVPECL RxREFCLK may be at 1/16 or 1/64 of the incoming data rate also.

Table 7 - Reference Clock characteristics

Parameter	Symbol	Min.	Typical	Max.	Unit	Notes
Transmitter						
Frequency	TxREFCLKP TxREFCLKN	155.52/622.08			MHz	Serial data-rate is 9.953Gbps
Frequency tolerance		-100		+100	ppm	
Rise/Fall time	Tr/Tf			500	ps	
Duty Cycle	T _{DC}	40	50	60	%	
Receiver						
Frequency	RxREFCLKP RxREFCLKN	155.52/622.08			MHz	Serial data-rate is 9.953Gbps
Frequency tolerance		-100		+100	ppm	
Rise/Fall time	Tr/Tf			500	ps	
Duty Cycle	T _{DC}	40	50	60	%	

Table 8 - Transmitter/Receiver Parallel Data/Clock Interface

Parameter	Symbol	Level	Notes
Transmitter 16-bit parallel Data Input	TxDin[0:15]P/N	LVDS	TxDin0:LSB, TxDin15:MSB
Transmitter Source synchronous Parallel Input Clock	TxPICKLKP/N	LVDS	
Transmitter Counter Clock	TxPCLKP/N	LVDS	
Receiver 16-bit parallel Data Output	RxDout[0:15]P/N	LVDS	RxDout0:LSB, RxDout15:MSB
Receiver Source synchronous Parallel Output Clock	RxPOCLKP/N	LVDS	

Table 9 - Transmitter/Receiver Parallel Data/Clock Timing

Parameter	Symbol	Min.	Typical	Max.	Unit	Notes
Transmitter Data/Clock Timing: SERDES Input Timing at SERDES pin						
TxPICKL	Duty Cycle(T_w/T_o)	T_{DC}	40	50	60	%
	Rise and Fall time	T_r/T_f	100		300	ps
TxDin	Setup time	T_s	250			ps
	Hold time	T_h	250			ps
<p>T_s: Measuring from the LHS inner data eye to the immediate rising edge of clock pulse T_h: Measuring from the rising edge of clock pulse to the inner RHS of data eye</p>						
Receiver Data/Clock Timing: SERDES Output Timing at SERDES pin						
RxPOCLK	Duty Cycle(T_w/T_o)	T_{DC}	40		60	%
	Rise and Fall time	T_r/T_f	100		250	ps
RxDout	Data/Clock skew	T_{cq_min}			200	ps
		T_{cq_max}			200	ps

Table 10 - Monitor Clock

Parameter	Symbol	Level	Notes
Transmitter monitor clock	TxMCLKP/N	LVDS	The LVDS TxMCLK is either a 1/16 or 1/64 replica of the clock used to time the serial data output. The rate of the TxMCLK is always the same as that of the TxREFCLK
Receiver monitor clock	RxMCLKP/N	LVDS	The LVDS RxMCLK is a 1/16 or 1/64 replica of the clock recovered from the incoming data

Digital Control Signal

Table 12 - Input Digital signals

Function	Symbol	Level	Description	Note	
Module RESET	MOD_RESET	LVTTTL	L	Module reset	Reset both Tx and Rx section (LVTTTL with pull-up resistor)
			H	Normal operation	
Transmitter					
Select the frequency of TxREFCLK	TxREFSEL	LVTTTL	L	1/64 data-rate	(LVTTTL with pull-up resistor)
			H	1/16 data-rate	
Enable internal Line Timing	TxLINETIMSEL	LVTTTL	L	Enable	(LVTTTL with pull-up resistor)
			H	Normal operation	
Enable/Disable Laser	LsENABLE	LVTTTL	L	Normal operation	(LVTTTL with pull-down resistor)
			H	Laser disabled	
MUX FIFO reset	TxFIFORES	LVTTTL	L	MUX FIFO reset	Internally TxFIFOERR is connected to TxFIFORES, TxFIFOERR will initiate a FIFO reset (LVTTTL with pull-up resistor)
			H	Normal operation	
Receiver					
Select the frequency of RxREFCLK	RxREFSEL	LVTTTL	L	1/64 data-rate	(LVTTTL with pull-down resistor)
			H	1/16 data-rate	
Select the frequency of RxMCLK	RxMCLKSEL	LVTTTL	L	1/64 data-rate	(LVTTTL with pull-up resistor)
			H	1/16 data-rate	
Lock RxPOCLK to RxREFCLK	RxLCKREF	LVTTTL	L	Lock to RxREFCLK	(LVTTTL with pull-up resistor)
			H	Normal operation	
Mutes the RxDOOUT[0:15]	RxMUTEDOUT	LVTTTL	L	Mutes the RxDOOUT[0:15]	(LVTTTL with pull-up resistor)
			H	Normal operation	
Mutes the receiver output monitor clock	RxMUTEMCLK	LVTTTL	L	Mutes the RxMCLK	(LVTTTL with pull-up resistor)
			H	Normal operation	
Mutes receiver parallel output clock RxPOCLK	RxMUTEPOCLK	LVTTTL	L	Mutes the RxPOCLK	(LVTTTL with pull-up resistor)
			H	Normal operation	

Digital Alarm Signal

Table 13 - Alarms Digital signals

Function	Symbol	Level	Description		Note
Common Digital Signal					
Indicates all alarm active	ALMINT	LVTTL	L	Any alarm from both transmitter and receiver	Activation Time: 10ms Deactivation Time: 10ms
			H	Normal operation	
Transmitter					
Loss of Tx PLL lock	TxLOCKERR	LVTTL	L	Alarm active	Loss of transmitter PLL lock Activation Time: 1ms Deactivation Time: 1ms
			H	Normal operation	
MUX FIFO error	TxFIFOERR	LVTTL	L	Alarm active (FIFO overflow)	Internally TxFIFOERR is connected to TxFIFOES,
			H	Normal operation	
Laser bias out of range	LsBIASALM	LVTTL	L	Alarm active (laser bias current alarm)	Alarm when laser bias changes by a factor of 2 from beginning of life or if monitor reaches maximum level corresponding to approximate 150mA. Activation Time: 10 ms Deactivation Time: 10 ms
			H	Normal operation	
Laser temperature out of range	LsTEMPALM	LVTTL	L	Alarm active	Laser temperature 5°C from nominal, Activation Time : 10ms Deactivation Time : 10ms
			H	Normal operation	
Laser output power out of range	LsPOWALM	LVTTL	L	Alarm active	Output power degrades 3dB below the BOL Activation Time : 10ms Deactivation Time : 10ms
			H	Normal operation	
Tx alarms	TxALMINT	LVTTL	L	Alarm from transmitter	Activation Time: 10 ms; Deactivation Time: 10 ms
			H	Normal operation	
Receiver					
Loss of Rx PLL lock	RxLOCKERR	LVTTL	L	Alarm active	Activation Time: 1ms Deactivation Time: 1ms
			H	Normal operation	
Loss of receiver average power alarm	RxPOWALM	LVTTL	L	Alarm active	Activation Time: <10ms Deactivation Time: <10ms
			H	Normal operation	
Rx alarms	RxALMINT	LVTTL	L	Alarm from transmitter	Activation Time: 10 ms; Deactivation Time: 10 ms
			H	Normal operation	

Analog Monitoring Signal

Table 14 - Monitor Signals

Function	Symbol	Min.	Typ.	Max.	Unit
Transmitter					
Normalized laser power monitor voltage BOL	LsPOWMON	0.47	0.5	0.53	V
Laser power monitor voltage slope		0.25 V change for 50% power variation			
Laser bias monitor voltage offset	LsBIASMON	0.2	0	2	V
Laser bias monitor voltage slope		18	20	22	mV/mA
Normalized laser temperature Monitor voltage	LsTEMPMON	2.4	2.5	2.6	V
Laser temperature Monitor voltage slop		23	25	27	mV/°C
Receiver					
Input optical power monitor voltage offset @-10dBm	RxPOWMON	0.6	0.8	1.0	mV
Input optical power monitor voltage slope			8.0		V/mW
Input optical power monitor error		-2		+2	dB

I2C Serial Interface

Table 14 – I2C Interface

Function	Symbol	Level	Description	Note
I2C Address	I2CAD0	LVTTL	I2C address input for module addressing (LSB)	(LVTTL with pull-down resistor)
	I2CAD1	LVTTL	I2C address input for module addressing	(LVTTL with pull-down resistor)
	I2CAD2	LVTTL	I2C address input for module addressing (MSB)	(LVTTL with pull-down resistor)
I2C Clock	I2CCLOCK	Open collector	I2C clock input/output for remote access	N/A
I2C Data	I2CDATA	Open collector	I2C data input/output for remote access	N/A

Pin Definitions

Table 15 - Pin Function Definitions

	K	J	H	G	F	E	D	C	B	A	
1	+5V	NUC	GND	RxDout12P	+1.8V	RxDout8P	GND	RxDout4P	GND	RxDout0P	
2	+5V	FFU	GND	RxDout12N	+1.8V	RxDout8N	GND	RxDout4N	GND	RxDout0N	
3	NUC	NUC	FFU	GND	RxPOWMON	GND	I2CAD0	GND	RxDTV	GND	
4	+3.3V	NUC	GND	RxDout13P	+3.3V	RxDout9P	GND	RxDout5P	GND	RxDout1P	
5	+3.3V	NUC	GND	RxDout13N	+3.3V	RxDout9N	GND	RxDout5N	GND	RxDout1N	
6	NUC	NUC	NUC	GND	RxPOWALM	GND	I2CAD1	GND	RxMUTE Dout	GND	
7	+3.3V	FFU	GND	RxDout14P	+3.3V	RxDout10P	GND	RxDout6P	GND	RxDout2P	
8	+3.3V	FFU	GND	RxDout14N	+3.3V	RxDout10N	GND	RxDout6N	GND	RxDout2N	
9	RxMUTEPOCLK	NUC	FFU	GND	FFU	GND	I2CAD2	GND	RxLCKREF	GND	
10	-5.2V	NUC	GND	RxDout15P	-5.2V	RxDout11P	GND	RxDout7P	GND	RxDout3P	
11	-5.2V	NUC	GND	RxDout15N	-5.2V	RxDout11N	GND	RxDout7N	GND	RxDout3N	
12	RxMUTEMCLK	NUC	FFU	GND	FFU	GND	MOD RESET	GND	RxMCLKSEL	GND	
13	-5.2V	FFU	GND	FFU	-5.2V	RxPOCLKP	GND	RxMCLKP	GND	RxREFCLKP	
14	-5.2V	RxALMINT	GND	FFU	-5.2V	RxPOCLKN	GND	RxMCLKN	GND	RxREFCLKN	
15	I2CCLOCK	NUC	FFU	GND	RxREFSEL	GND	FFU	GND	RxLOCKERR	GND	
16	+5V	TxALMINT	GND	TxDin12P	+1.8V	TxDin8P	GND	TxDin4P	GND	TxDin0P	
17	+5V	FFU	GND	TxDin12N	+1.8V	TxDin8N	GND	TxDin4N	GND	TxDin0N	
18	I2CDATA	NUC	FFU	GND	LsBIASMON	GND	LsPOWMON	GND	NUC	GND	
19	+3.3V	FFU	GND	TxDin13P	+3.3V	TxDin9P	GND	TxDin5P	GND	TxDin1P	
20	+3.3V	FFU	GND	TxDin13N	+3.3V	TxDin9N	GND	TxDin5N	GND	TxDin1N	
21	NUC	NUC	FFU	GND	LsENABLE	GND	LsTEMPMON	GND	NUC	GND	
22	+3.3V	FFU	GND	TxDin14P	+3.3V	TxDin10P	GND	TxDin6P	GND	TxDin2P	
23	+3.3V	FFU	GND	TxDin14N	+3.3V	TxDin10N	GND	TxDin6N	GND	TxDin2N	
24	NUC	NUC	FFU	GND	LsBIASALM	GND	FFU	GND	FFU	GND	
25	-5.2V	NUC	GND	TxDin15P	-5.2V	TxDin11P	GND	TxDin7P	GND	TxDin3P	
26	-5.2V	NUC	GND	TxDin15N	-5.2V	TxDin11N	GND	TxDin7N	GND	TxDin3N	
27	TxFIFORES	NUC	NUC	GND	LsTEMPALM	GND	FFU	GND	TxPICKSEL	GND	
28	-5.2V	FFU	GND	TxPICKLP	-5.2V	TxPCLKP	GND	TxMCLKP	GND	TxREFCLKP	
29	-5.2V	TxTRACE	GND	TxPICKLN	-5.2V	TxPCLKN	GND	TxMCLKN	GND	TxREFCLKN	
30	TxFIFOERR	NUC	LINETIMESEL	GND	TxREFSEL	GND	LsPOWALM	GND	TxLOCKERR	GND	
FFU: Reserved for Future Use				NUC: No Use Connection							

Mechanical Design Diagram

The mechanical design diagram is shown in Figure 2.

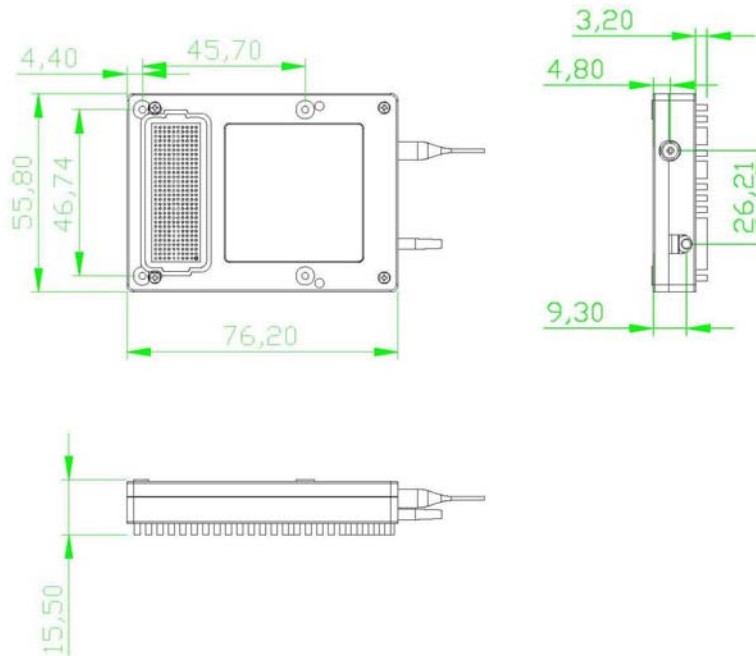

Note: the fiber length is 100+/-10cm.

Figure 2, Mechanical Diagram (Unit: mm)

Ordering Information

Part No.	Product Description
TP-TS-08-CDL5A	1550nm, 9.953Gbps, 80km, SFF 300pin, LC connector, -5°C~+70°C,
TP-TS-08-CDS5A	1550nm, 9.953Gbps, 80km, SFF 300pin, SC connector, -5°C~+70°C,

Related Documents

For further information, please refer to the following documents:

- Application Note for Fiberxon 10G Transponder I2C Serial Interface Specifications
- Reference Document for 300 pin Multi Source Agreement for 10 Gigabit Transponders (SERDES Transceivers), Edition 4, August 14, 2002
- I2C Reference Document for 300-PIN MSA 10G and 40G Transponders, Edition 4, July 24, 2002.

Obtaining Document

You can visit our website:

<http://www.SourcePhotonics.com>

Or contact with Source Photonics, Inc. America Sales Office listed at the end of documentation to get the latest documents.

Revision History

Revision	Initiate	Review	Approve	Subject	Release Date
Rev. 1a	Andy.Xiao	Jashon.Wang	Walker.We	Initial datasheet	Oct .09, 2008
Rev.02	Andy.Xiao	Jashon.Wang	Walker.We	Update mechanical diagram	Nov.23, 2009

© Copyright Source Photonics Inc. 2008

All Rights Reserved.

All information contained in this document is subject to change without notice. The products described in this document are NOT intended for use in implantation or other life support applications where malfunction may result in injury or death to persons.

The information contained in this document does not affect or change Source Photonics product specifications or warranties. Nothing in this document shall operate as an express or implied license or indemnity under the intellectual property rights of Source Photonics or third parties. All information contained in this document was obtained in specific environments, and is presented as an illustration. The results obtained in other operating environment may vary.

THE INFORMATION CONTAINED IN THIS DOCUMENT IS PROVIDED ON AN "AS IS" BASIS. In no event will Source Photonics be liable for damages arising directly from any use of the information contained in this document.

Contact

U.S.A. Headquarters
 20550 Nordhoff Street
 Chatsworth, CA91311

Tel: 818.773.9044

Fax: 818.773.0261

M-S@sourcephotonics.com.cn